

# 8916 Power Tube

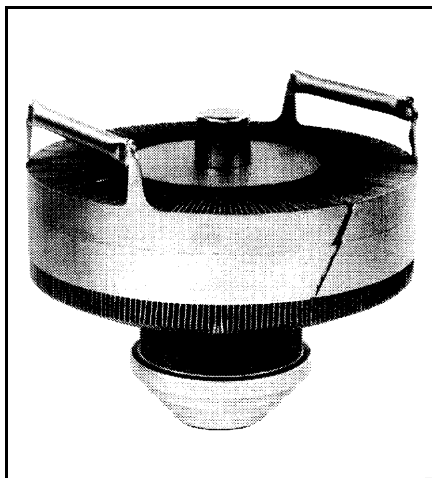

## VHF Linear Power Amplifier Tube

27.5 Kilowatt Peak Sync. Output Thru VHF-TV Band

- 13 dB Gain
- High Gain-Bandwidth Products
- Efficient Forced-Air Cooling
- Full Input to 400 MHz
- CERMOLOX® Construction

The BURLE 8916 is designed specifically for use in high-gain, high-linearity equipments for VHF-TV and FM service and for communication transmitters to 400 MHz.

In VHF-TV service at 223 MHz, the 8916 can deliver up to a full 27.5 kilowatt peak sync output with 6.3 MHz bandwidth and 13 dB gain.

Rated for full input for the VHF-TV band and for other service to 400 MHz, the 8916 can be readily circuited for these frequencies. The terminals are coaxial for operation in the TEM<sub>00</sub> mode and the radiator location avoids restricting the resonant cavity circuits in UHF operation. The 8916 assures high gain-bandwidth products for the full VHF-TV band. In addition, it is well suited for other applications such as single sideband, CW or pulsed RF and modulator service and for FM broadcast service.

This data sheet gives application information unique to the BURLE 8916. Important additional information of a general nature, applicable to tubes of this type, is given in the following publications:

- TP-105 Application Guide for BURLE Power Tubes
- TP-117 Handling and Operating Considerations when Using BURLE Tetrodes
- TP-118 Application Guide for Forced Air Cooling BURLE Power Tubes

Close attention to the instructions contained therein will assure longer tube life, safer operation, less equipment downtime and fewer tube handling accidents.

For specific information or application assistance, contact your nearest BURLE Sales Representative or write Power Tube Marketing, BURLE INDUSTRIES, INC., Lancaster, PA 17601.

### General Data

Electrical			
Filamentary Cathode, Thoriated-Tungsten Mesh Type:			
Voltage <sup>1</sup> (AC or DC) .....	9.5	typ.	V
	10.0	max.	V
Current:			
Typical value at 9.5 volts <sup>2</sup> .....	147		A
Maximum value for starting, even momentarily .....	300		A
Cold resistance .....	0.01		ohm
Minimum heating time <sup>3</sup> .....	15		s
Mu-Factor <sup>4</sup> (Grid No.2 to Grid No.1) .....	12.5		
Direct Interelectrode Capacitances:			
Grid No. 1 to plate <sup>5</sup> .....	0.4	max.	pF
Grid No.1 to filament .....	100		pF
Plate to filament <sup>5</sup> .....	0.15	max.	pF
Grid No.1 to grid No.2 .....	92		pF
Grid No.2 to plate .....	17.2		pF
Grid No.2 to filament <sup>6</sup> .....	4.0	max.	pF

Mechanical	
Operating Attitude .....	Vertical, either end up
Overall Length (Max.) .....	180.3 mm (7.10 in)
Greatest Diameter (Max.) .....	212.1 mm (8.349 in)
Socket .....	CD 89-094 <sup>7</sup> or equivalent
Chimney .....	9224 <sup>7</sup> or equivalent
Radiator .....	Integral part of tube
Weight (Approx.) .....	10.0 kg (22 lbs)

Thermal	
Seal Temperature <sup>8</sup> .....	250 max. °C
(Plate, Grid No.2, Grid No.1, Cathode-Filament, and Filament)	
Plate-Core Temperature <sup>8,9</sup> .....	250 max. °C

## RF Power Amplifier Class B Television Service<sup>10</sup>

Synchronizing-level conditions per tube unless otherwise specified.

### Maximum CCS Ratings, Absolute-Maximum Values

DC Plate Voltage <sup>11</sup> .....	13,000	V
DC Grid-No.2 Voltage <sup>12</sup> .....	2,000	V
DC Grid-No.1 Voltage <sup>14</sup> .....	-600	V
DC Plate Current .....	7.0	A
Grid-No.2 Input .....	250	W
Grid-No. 1 Input .....	150	W
Plate Dissipation .....	See Notes 9 & 13	

### Typical CCS Operation

In a cathode-drive circuit at 216 MHz and a bandwidth of 6.3 MHz<sup>15</sup>

DC Plate Voltage .....	7,800	V
DC Grid-No.2 Voltage .....	1,000	V
DC Grid-No.1 Voltage <sup>17</sup> .....	-95	V
Zero Signal DC Plate Current .....	1.25	A
Effective RF Load Resistance .....	670	ohms
DC Plate Current:		
Synchronizing level .....	5.85	A
Blanking level .....	4.50	A
DC Grid-No.2 Current:		
Synchronizing level .....	170	mA
Blanking level .....	.25	mA
DC Grid-No.1 Current:		
Synchronizing level .....	900	mA
Blanking level .....	320	mA
Input Circuit Efficiency (Approx.) .....	95	%
Driver Power Output:		
Synchronizing level .....	1,130	W
Blanking level .....	620	W
Output Circuit Efficiency (Approx.) .....	95	%
Useful Power Output:		
Synchronizing level .....	27,500	W
Blanking level .....	15,500	W

## RF Power Amplifier Class B, FM Telephony<sup>10</sup> Class B, Telegraphy

### Maximum CCS Ratings, Absolute-Maximum Values

DC Plate Voltage <sup>11</sup> .....	13,000	V
DC Grid-No.2 Voltage <sup>12</sup> .....	2,000	V
DC Grid-No.1 Voltage .....	-600	V
DC Plate Current .....	6.0	A
DC Grid-No.2 Input .....	250	W
DC Grid-No.1 Input .....	150	W
Plate Dissipation .....	See Notes 9 & 13	

### Typical, Grid-Driven, Class B, FM Telephony<sup>19</sup>

DC Plate Voltage .....	12,000	V
DC Grid-No.2 Voltage .....	1,300	V
DC Grid-No.1 Voltage <sup>17</sup> .....	-200	V
Zero Signal DC Plate Current .....	250	mA
Effective RF Load Resistance .....	1,280	ohms
DC Plate Current .....	4.1	A
DC Grid-No.2 Current .....	20	mA
DC Grid-No.1 Current .....	100	mA
Grid Loading Resistance .....	750	ohms
Driver Power Output <sup>20</sup> .....	60	W
Useful Power Output .....	30	kW

## Typical, Grid-Driven, Class B, CCS Telegraphy

7.0 MHz

DC Plate Voltage .....	12,000	V
DC Grid-No.2 Voltage .....	1,300	V
DC Grid-No.1 Voltage <sup>17</sup> .....	-200	V
Zero Signal DC Plate Current .....	250	mA
Effective RF Load Resistance .....	1,280	ohms
DC Plate Current .....	4.7	A
DC Grid-No.2 Current .....	90	mA
DC Grid-No.1 Current .....	200	mA
Grid Loading Resistance .....	750	ohms
Driver Power Output <sup>20</sup> .....	100	W
Useful Power Output .....	40	kW

1. Measured at the tube terminals. For accurate data the ac filament voltage should be measured using an accurate RMS type meter such as an iron-vane or thermocouple type meter. The dc voltage should be measured using a high input impedance type meter.  
For high-current, low-voltage filaments such as are used in the 8916, it is recommended that the filament current be monitored since very small changes in resistance can produce misleading changes in voltage. For maximum life, the filament power should be regulated at the lowest value that will give stable performance. For those applications where hum is a critical consideration, dc filament or hum-bucking circuits are recommended.
2. The characteristic range of current at 9.5 volts is from 136 to 156 amperes. It is recommended that an additional seven amperes be available to allow for the normal reduction of filament resistance with life. Thus the filament supply should be designed for a mean value of 163 amperes at 9.5 volts.
3. With special surge-limiting precautions in the filament circuit, the warm-up time may be reduced to three seconds, The sequence for applying voltage is as follows:  
Filament  
Bias  
Plate  
Screen  
RF Drive
4. For plate voltage = 2000 V, grid-No.2 voltage = 1250 V, and plate current = 15 A.
5. With external flat metal shield 8" (200 mm) in diameter having a center hole 3" (76 mm) in diameter. Shield is located in plane of the grid-No.2 terminal, perpendicular to the tube axis, and is connected to grid No.2.
6. With external flat metal shield 8" (200 mm) in diameter having a center hole 2-3/8" (60 mm) in diameter. Shield is located in plane of the grid-No.1 terminal, perpendicular to the tube axis, and is connected to grid No.1.
7. As manufactured by: Jettron Products Inc., 56 Route Ten, Hanover, N.J. 07936
8. See Dimensional Outline for Temperature Measurement Points.
9. The value of 250 °C is the average of three readings taken 120° apart around the top of the anode core. No one reading may exceed 275 °C.
10. See TP-105.
11. See TP-105.

The maximum voltage ratings must be modified for operation at altitudes higher than sea level and for temperatures in excess of 20° C in accordance with the curves of **Figure 2**.

The maximum fault energy that can be dissipated within the tube is approximately 100 joules. Therefore, the energy available for a high-voltage arc or fault must be limited to this value by means of current limiting resistors or fault-protection circuitry. This is especially important in pulse service where high, stored energy and

large capacitors are used. In typical 25 kW TV transmitters, the series resistors used are:

- plate = 10 ohms
- screen = 30 to 50 ohms
- grid = 50 ohms

For additional information see TP-105 "Application Guide for BURLE Power Tubes".

- 12 See TP-105.
- 13 Permitted plate dissipation is a function of cooling. For specific ratings see Forced Air Cooling information in this data sheet.
- 14 See TP-105.
15. The bandwidth of 6.3 MHz is calculated at the -0.72 dB power points of a double tuned output circuit using two times the tube output capacity and a damping factor of  $\sqrt{1.5}$  as shown in **Figure 2**.  
Obtained from a fixed supply with an internal impedance of 710 ohms to provide necessary increase in bias at crest of modulating signal.
17. Adjust for specified zero-signal dc plate current.
18. Drive power output represents circuit losses and is the actual power measured at the input to the grid-No.1 circuit. The actual power required depends on the operating frequency and the circuits used. The tube driving power is approximately zero watts.
19. Measured at 7.0 MHz.
20. Driver power output represents circuit losses in the driver output circuit and the grid input circuit in addition to the power necessary to drive the tube.

## Protection Circuits

Protection circuits serve a threefold purpose: safety of personnel, protection of the tube in the event of abnormal circuit operation, and protection of the tube circuits in the event of abnormal tube operation.

Power tubes require mechanical protective devices such as interlocks, relays, and circuit breakers. Circuit breakers alone may not provide adequate protection in certain power-tube circuits when the power-supply filter, modulator, or pulse-forming network stores much energy. Additional protection may be achieved by the use of high-speed electronic circuits to bypass the fault current until mechanical circuit breakers are opened. These circuits may employ a control gas tube, such as a thyratron or ignitron, depending on the amount of energy to be handled.

Operating voltages applied to this device present a shock hazard and appropriate precautions should be taken. Great care should be taken during the adjustment of circuits. The tube and its associated apparatus, especially all parts which may be at high potential above ground, should be housed in a protective enclosure. The protective housing should be designed with interlocks so that personnel can not possibly come in contact with any high-potential point in the electrical system. The interlock devices should function to break the primary circuit of the high-voltage supplies and discharge high-voltage capacitors when any gate or door on the protective housing is opened, and should prevent the closing of this primary circuit until the door is again locked.

A time-delay relay should be provided in the plate-supply circuit to delay application of plate voltage until the filament has reached normal operating temperature.

An interlocking relay system should be provided to prevent application of plate voltage prior to the application of sufficient

bias voltage otherwise, with insufficient bias, the resultant high plate current may cause excessive plate dissipation with consequent damage to the tube. RF load shorts or other causes of high output VSWR may also cause high dissipations, excessive voltage gradients, or insulator flashover. The load VSWR should be monitored and the detected signal used to actuate the interlock system to remove the plate voltage in less than 10 milliseconds after the fault occurs.

## Forced Air Cooling

Cooling air flow is necessary to limit the anode-core and terminal-seal temperatures to values that will assure long reliable life. A sufficient quantity of air should be directed past each of these terminals so that its temperature does not approach the absolute-maximum limit. The absolute-maximum temperature rating for this tube is 250° C. It is recommended that a safety factor of 25° to 50° be applied, to compensate for all probable system and component variations throughout life.

The cooling air must be delivered by the blower through the radiator and at the terminal seals during the application of power and for a minimum of three minutes after the power has been removed.

**To Cathode-Filament and Filament Terminals -** A sufficient quantity of air should be blown directly at these terminals so that their temperature does not approach the absolute-maximum limit of 250° C. A value of at least 60 cfm is recommended.

The Cooling Characteristic Curve, **Figure 7**, indicates the air flow and pressure requirements of a system sufficient to limit the core temperature to specific values for various levels of plate dissipation.

Because the cooling capacity of air varies with its density, factors must be applied to the air flow to compensate for operation at altitude or in high temperature environments.

During Standby Operation - Cooling air is required when only the filament voltage is applied to the tube.

For further information on forced air cooling, see TP-105 and also TP-118 "Application Guide for Forced Air Cooling of BURLE Power Tubes".

## Mounting

The preferred mounting arrangement is depicted in **Figure 9**. Other arrangements, such as cavity-type mounting, for multiple-terminal tubes may be constructed using the adjustable or floating contact rings in the transverse plane.

Ready made sockets and chimneys may be obtained in production quantities from: Jettron Products, Inc., 56 Route Ten, Hanover, N.J. 07986

Part	Jettron No.
Socket	CD 89-094
Chimney	9224

## Tube Removal From Socket (Suggested Method)

The tube should not be removed from the socket by rocking the tube back and forth. This motion crushes the contact fingers and applies undue force to the internal structure of the tube.

It is recommended that the tube be removed from the socket with an assembly similar to that shown in **Figure 10**. The extractor plate should be constructed with the dimensions shown in **Figure 11**.

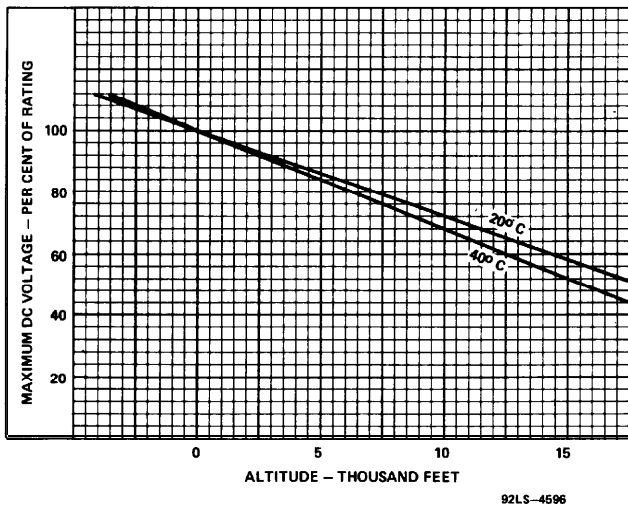

Figure 1 - Maximum DC Voltage with Respect to Altitude

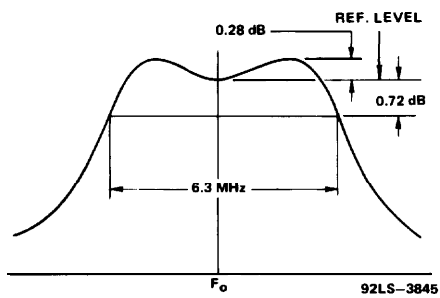

Figure 2 - Bandwidth Calculation

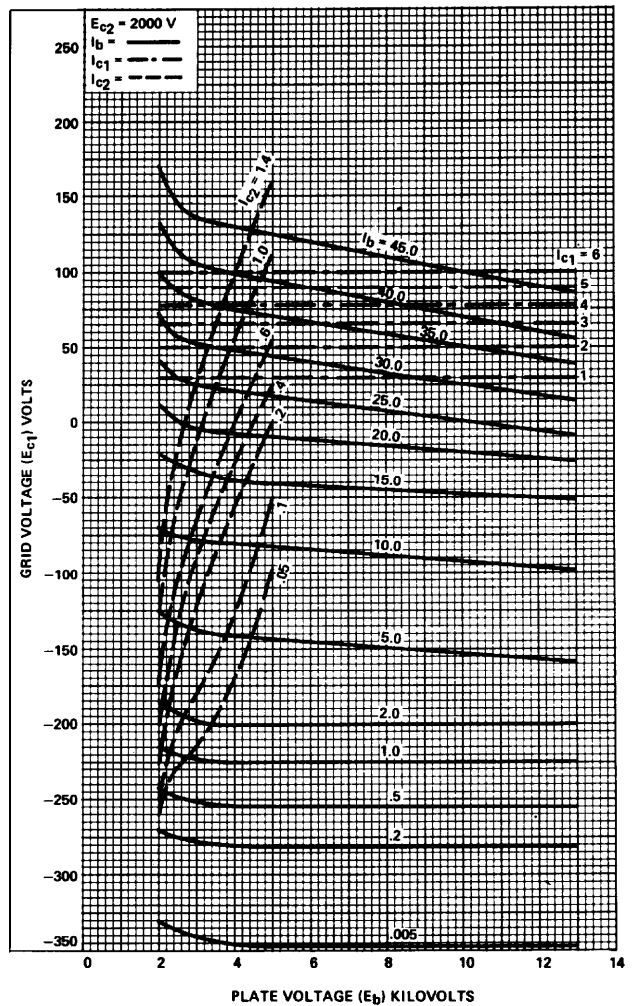

Figure 3 - Typical Constant Current Tube Characteristics  
@  $E_{c2} = 2000$  v

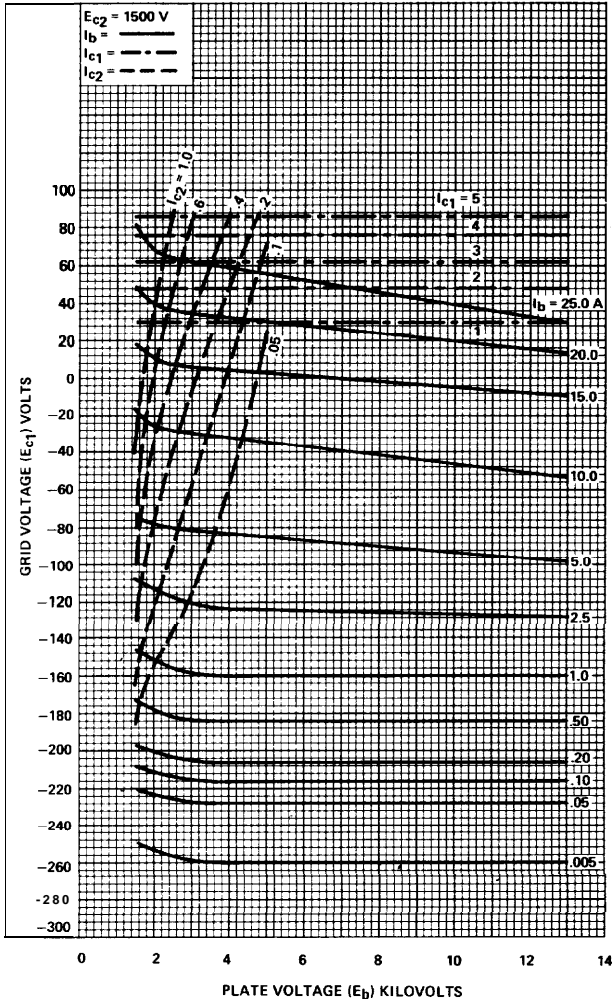

Figure 4 - Typical Constant Current Tube Characteristics  
@  $E_{c2} = 1500$  V

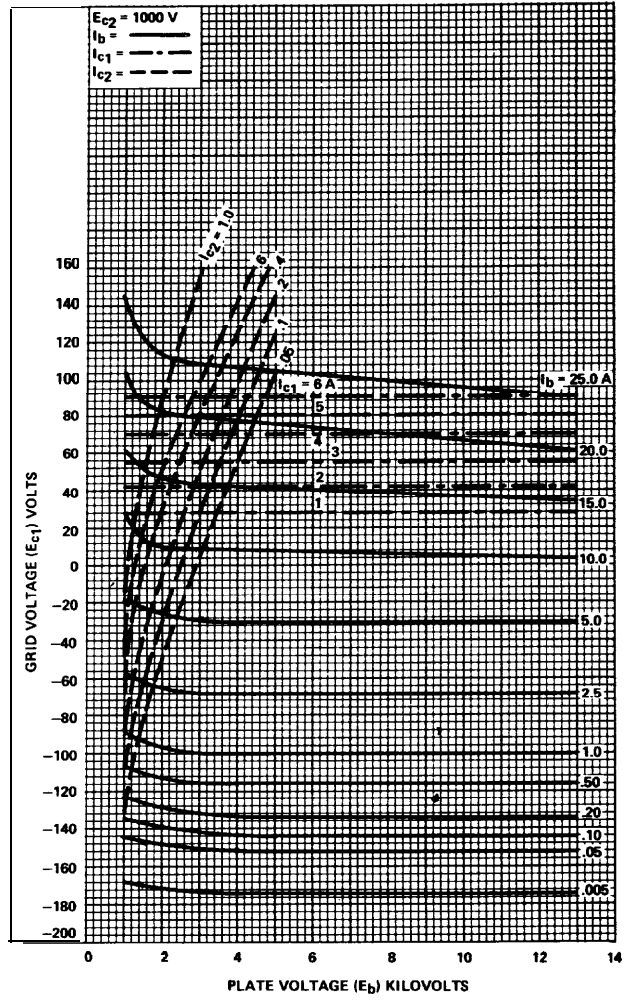
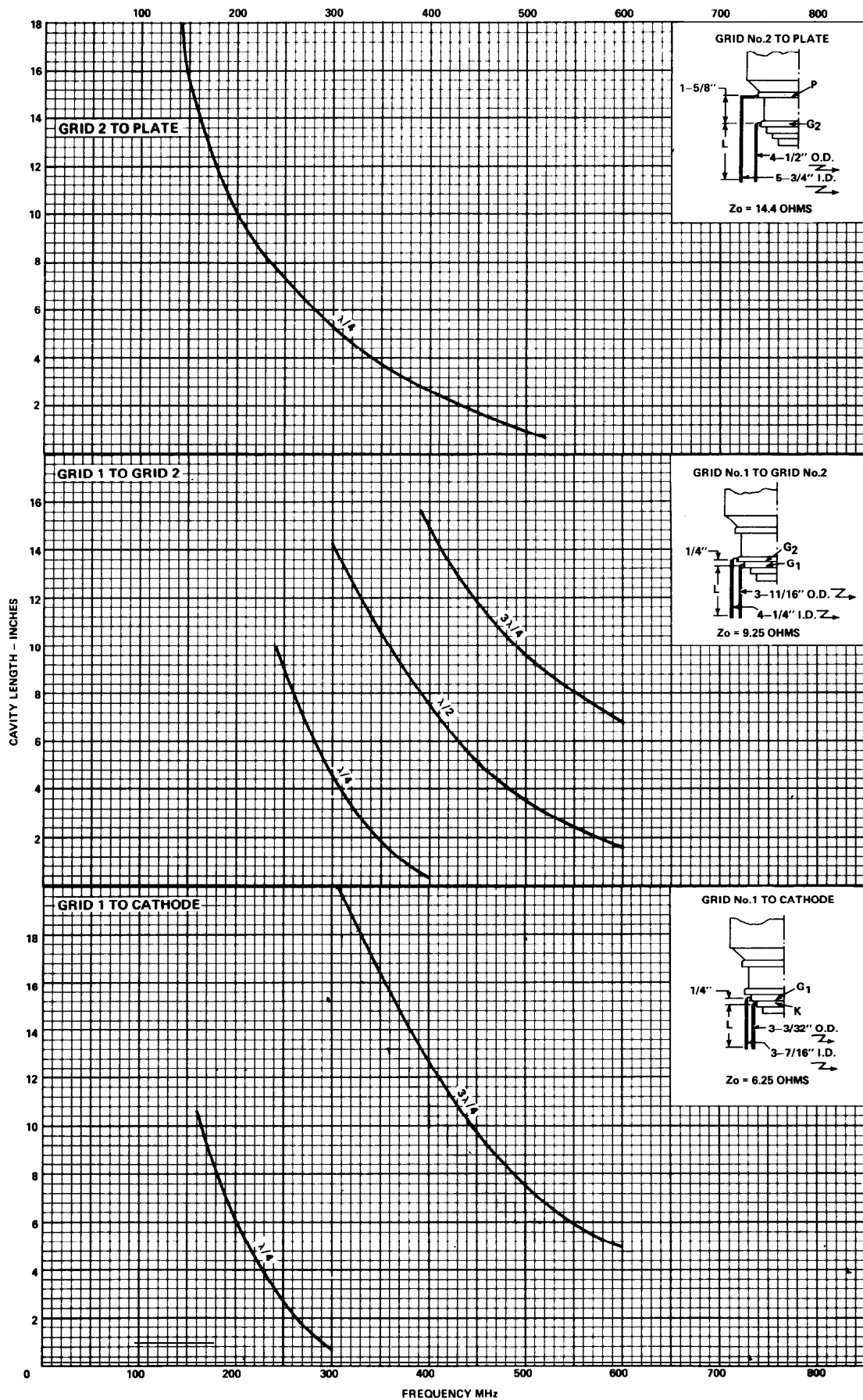

Figure 5 - Typical Constant Current Tube Characteristics  
@  $E_{c2} = 1000$  V



92LL-3689R1

Figure 6 - Electrode Cavity Tuning Characteristics

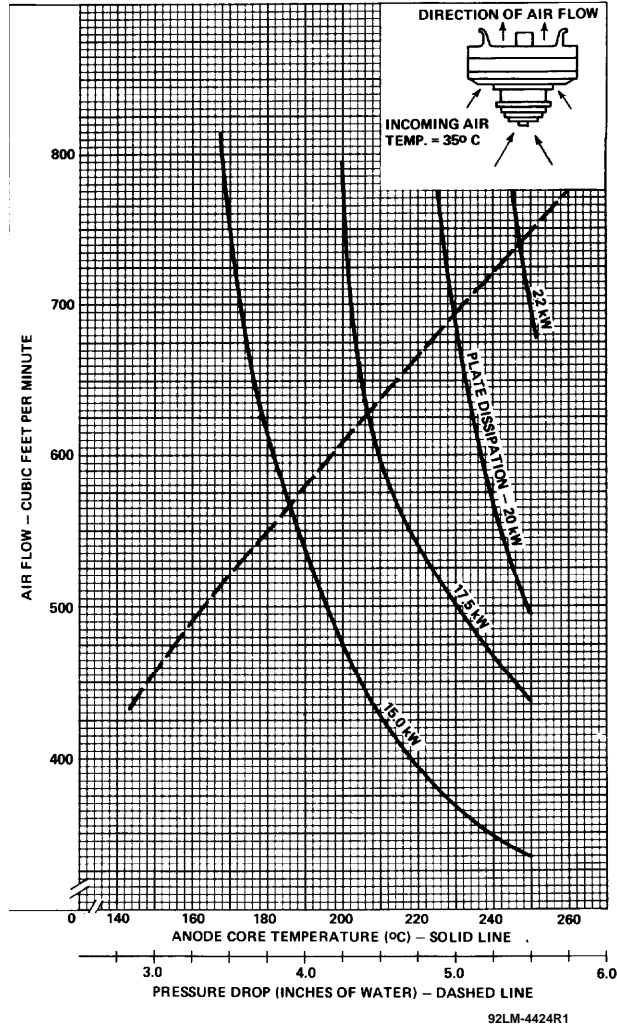
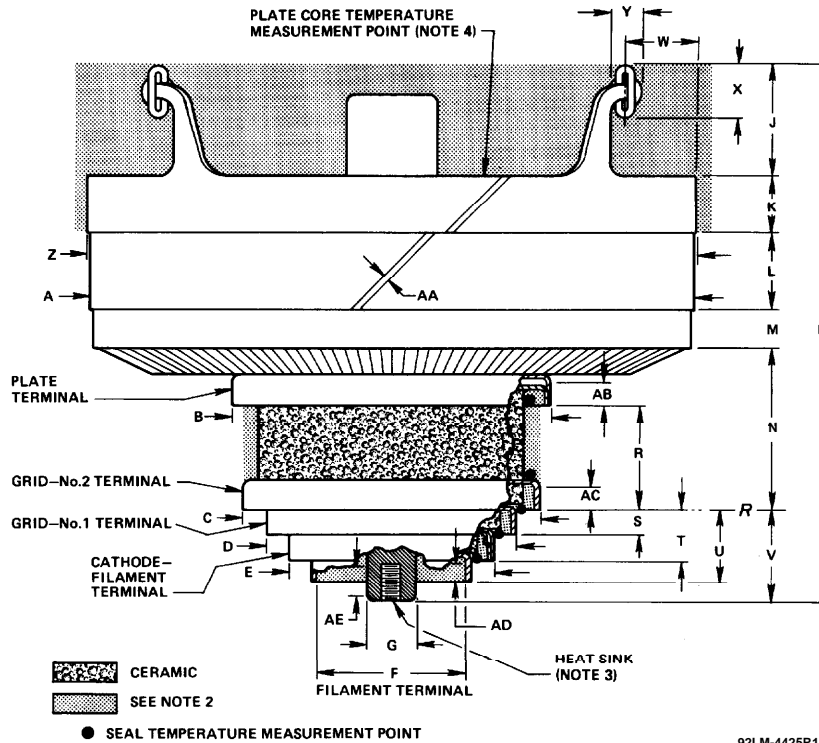

Figure 7 - Typical Cooling Characteristics

92LM-4424R1



### Tabulated Dimensions

Dimensions	Millimeters	Inches	Notes
A Dia.	209.55 ± .89	8.250 ± .035	1, 5
B Dia.	106.38 ± .51	4.188 ± .020	1, 5
C Dia.	99.44 ± .38	3.915 ± .015	1, 5
D Dia.	84.20 ± .38	3.315 ± .015	1, 5
E Dia.	68.48 ± .38	2.696 ± .015	1, 5
F Dia.	49.78 ± .38	1.960 ± .015	1, 5
G Dia.	20.57 max.	0.810 max.	1, 5
H	180.34 max.	7.100 max.	
J	33.27 ref.	1.310 ref.	
K	19.05 max.	0.750 max.	
L	25.40 ref.	1.000 ref.	
M	13.72 ref.	0.540 ref.	
N	54.6 ± 1.3	2.150 ± .050	
P	45.09 min.	1.775 min.	
R	36.07 ± .76	1.420 ± .030	
S	8.38 ± .76	0.330 ± .030	
T	16.51 ± .97	0.650 ± .038	
U	24.4 ± 1.3	0.960 ± .050	
V	30.48 ref.	1.200 ref.	
W	20.32 ref.	0.800 ref.	
X	19.05 max.	0.750 max.	
Y	11.10 ref.	0.437 ref.	
Z	211.18 ± .89	8.314 ± .035	
AA	1.57 ref.	0.062 ref.	
AB	6.73 min.	0.265 min.	1
AC	6.73 min.	0.265 min.	1
AD	6.73 min.	0.265 min.	1
AE	11.43 min.	0.450 min.	1

Figure 8 - Dimensional Outline

**Note 1** - The diameter of each terminal is maintained only over the indicated minimum length of its contact surface.

**Note 2** - Keep all stippled regions clear. In general do not allow contacts to protrude into these annular regions. If special connectors are required which may intrude on these regions, contact BURLE Power Tube Application Engineering, Lancaster, PA 17601.

**Note 3** - Tapped 1/4-20 NC x 12.7 mm (0.5") deep.

**Note 4** - Plate core temperature measurement point is located on the plate itself and not at the fins.

**Note 5** - With the plate terminal and the cathode-filament terminal used as reference, the other terminals will measure less than 1.02 mm (0.040") total indicator run-out (TIR).



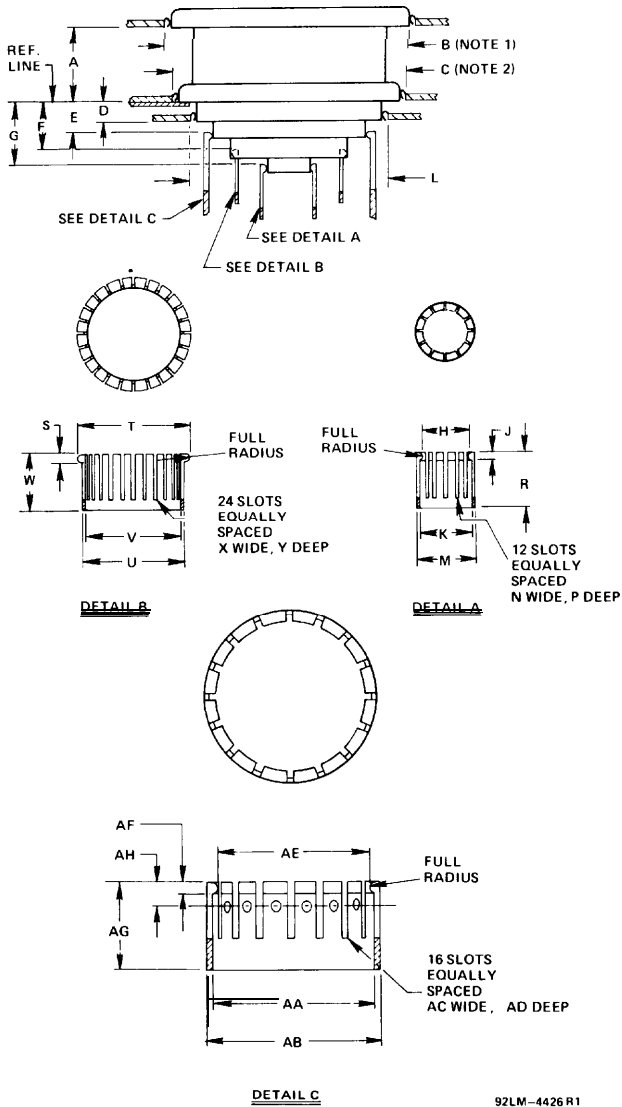

### Tabulated Dimensions

Dimensions	Millimeters	Inches
A	33.53	1.320
B	112.27 +.25, -00	4.420 +.010, -000
C	104.39 +.25, -00	4.110 +.010, -000
D	8.38	0.330
E	11.81	0.465
F	19.69	0.775
G	22.86	0.900
H	19.84 +00, -.05	0.781 +000, -.002
J	3.18	0.125
K	22.23	0.875
L	89.15 +.25, -00	3.510 +.010, -000
M	25.40	1.000
N	0.38	0.015
P	19.05	0.750
R	24.13 min.	0.950 min.
S	3.18	0.125
T	50.17 +.05, -00	1.975 +.002, -000
U	46.02	1.812
V	44.45	1.750
W	31.75 min.	1.250 min.
X	1.57	0.062
Y	19.05	0.750
AA	72.14	2.840
AB	76.20	3.000
AC	3.18	0.125
AD	25.40	1.000
AE	68.10 ±.05	2.681 ±.002
AF	3.18	0.125
AG	40.64 min.	1.600 min.
AH	10.16	0.400

**Note 1** - Finger stock is No.97-139 as made by Instrument Specialties Co., P.O.Box A, Delaware Water Gap, PA 18327

**Note 2** - Finger stock is No.97-135A as made by Instrument Specialties Co., P.O.Box A, Delaware Water Gap, PA 18327

**Figure 9 - Preferred Mounting Arrangement**

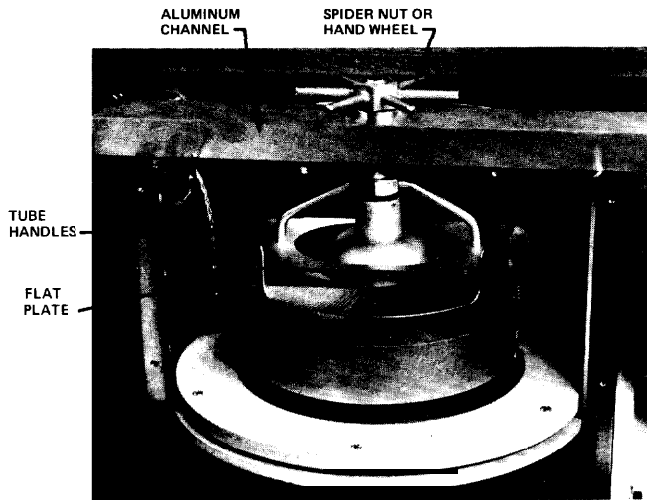
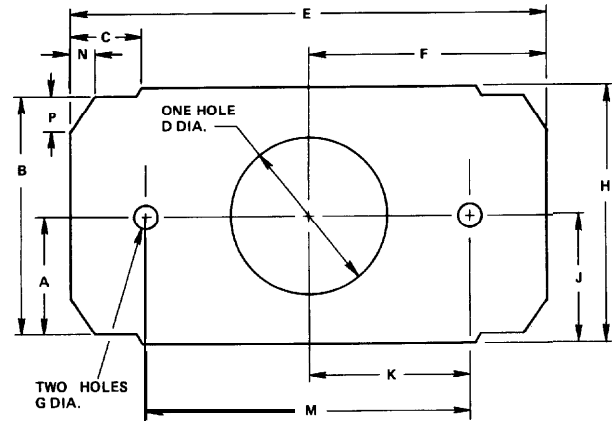

Figure 10 - Tube Removal Assembly



Tabulated Dimensions

Dimensions	Millimeters	Inches
A	47.63	1.875
B	95.25	3.750
C	28.58	1.125
DDia.	60.33	2.375
E	190.50	7.500
F	93.65	3.687
G Dia.	6.53	0.257
H	101.60	4.000
J	50.80	2.000
K	63.50	2.500
M	127.00	5.000
N	9.53	0.375
P	12.70	0.500

Figure 11 - Extractor Plate